



Digital Crane Scale

Blue Arrow XZ-GGE-Plus Crane Scale



Remote Control

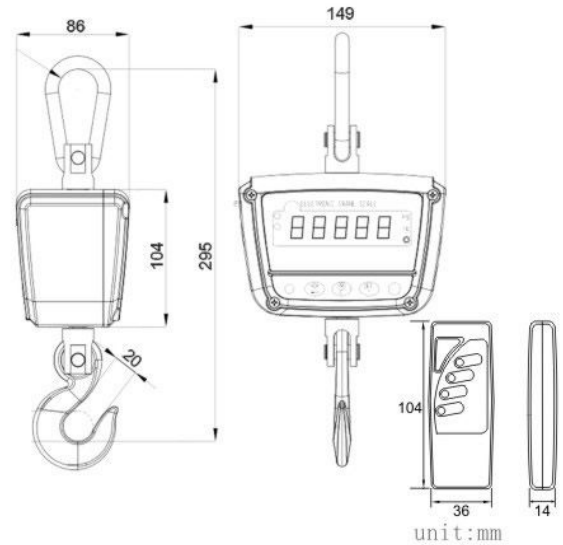

kN
lb kg
Lb/kg/kN
selectable

Built-in
beeper

CE FC

IP65

LFP
battery

Features

- Aluminum diecasting alloy housing with high strength and pleasant appearance
- 360° safe rotated hook and shackle
- IP65 industrial grade to protect from extremely environment
- Built-in long-life environmental lithium-iron battery
- Exclusive patent load cell, better than 1/3000 division

LED Display



Technical Specifications

Executive Standard: GB/T 11883-2002
 Accuracy: III OIML R76
 Time to Stable Reading: $\leq 8s$
 Maximum Safe Load: 150%F.S.
 Ultimate Overload: 500%F.S.
 Overload Alarm: 100%F.S.+9e
 Operating Temperature: $-10^{\circ}\text{C} - 40^{\circ}\text{C}$
 Storage Temperature: $-20^{\circ}\text{C} - 60^{\circ}\text{C}$

Max Capacity	Division	Weight
30kg	0.01/0.005kg	1.5kg
50kg	0.02/0.01kg	1.5kg
100kg	0.05/0.02kg	1.5kg
150kg	0.05/0.02kg	1.5kg
200kg	0.1/0.05kg	1.5kg
300kg	0.1/0.05kg	1.5kg

Distributor (US and Canada)
Optoco Inc.
 600 - 2498 West 41st Ave
 Vancouver, BC, V6M 2A7
 Tel: 778-706-6933
 Email: info@optoco.ca
 Web: www.crane-scale.com

Specifications are subject to change without notice.