

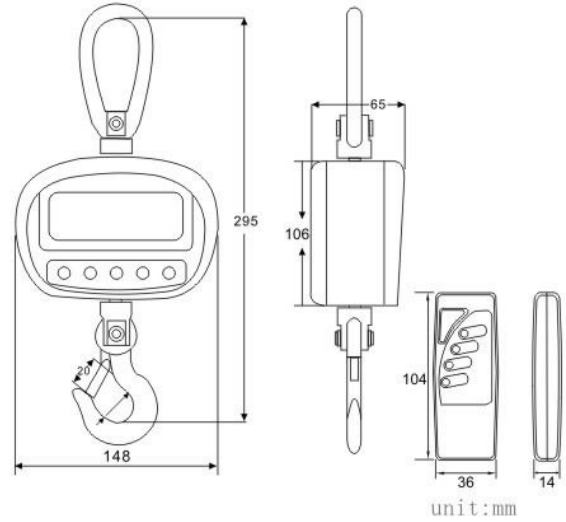

Digital Crane Scale

Blue Arrow XZ-GSC Crane Scale



kN
 lb kg

Applicable in day and night

Built-in beeper

AA battery

Features

- Attractive designing with light engineering plastic housing
- Convenient 360° swivel shackle and hook
- Exclusive patent load cell, high accuracy
- With AA battery, built-in lithium battery or Ni-H battery selectable
- Selectable division value and weight unit
- Infrared control for your selection



Remote Controller

Technical Specifications

Executive Standard: GB/T 11883-2002

Accuracy: $\pm 0.1\%$ OIML R76

Time to Stable Reading: $\leq 8s$

Maximum Safe Load: 150%F.S.

Ultimate Overload: 500%F.S.

Overload Alarm: 100%F.S.+9e

Operating Temperature: $-10^{\circ}C \sim 40^{\circ}C$

Storage Temperature: $-20^{\circ}C \sim 60^{\circ}C$

LCD Display

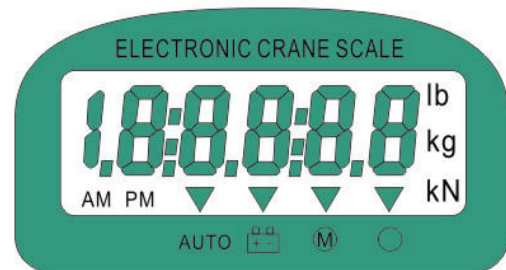

Max Capacity	Division	Weight
50kg	0.02/0.01kg	1kg
100kg	0.05/0.02kg	1kg
150kg	0.05/0.02kg	1kg
200kg	0.10/0.05kg	1kg
300kg	0.10/0.05kg	1kg

Distributor (US and Canada)
Optoco Inc.
 600 - 2498 West 41st Ave
 Vancouver, BC, V6M 2A7
 Tel: 778-706-6933
 Email: info@optoco.ca
 Web: www.crane-scale.com

Specifications are subject to change without notice.